

**GENERAL NOTES:**

ACTUAL TRACK LENGTHS ARE 1" LESS THAN 2X THE NOMINAL DOOR WIDTH (i.e., A 36" WIDE DOOR WOULD HAVE A 71" TRACK).

TRACK STANDOFFS ARE AVAILABLE FOR DOORS UP TO 2-1/4" THICK.

DOORS MORE THAN 1" OVER TYPICAL SIZES (i.e. 37" ON A NOMINAL 6" TRACK) REQUIRE THE TYPICAL HANGER OFFSET BE ALTERED. SEE INSTALLATION CUT SHEET FOR MORE INFORMATION.

IF YOUR DOOR IS A CUSTOM SIZE (i.e. 40"), YOU WILL HAVE TO REPOSITION ONE END STOP, DRILL ONE HOLE AT DESIRED LOCATION AND USE HEX BOLT TO FASTEN (NOT INCLUDED). YOU MAY ALSO USE ADJUSTABLE END STOPS (OPTIONAL ACCESSORY) OR REQUEST A CUSTOM FABRICATION.

FOR BI-PARTING DOORS, BUTT THE TRACK OF EACH KIT END TO END TIGHTLY. JOINING TRACKS IS NOT NECESSARY.

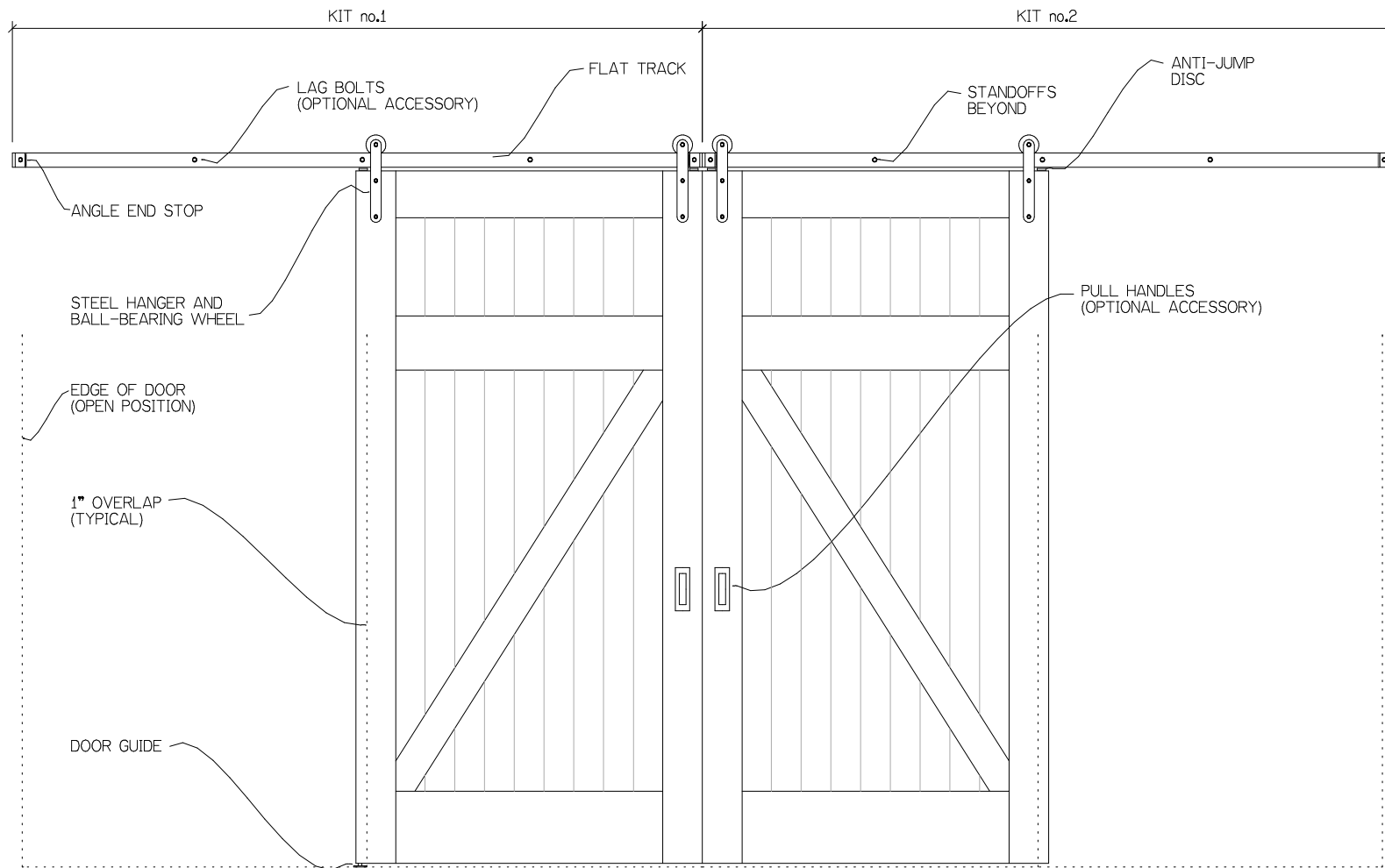

**GENERAL NOTES:**

ACTUAL TRACK LENGTHS ARE 1" LESS THAN 2X THE NOMINAL DOOR WIDTH (i.e., A 36" WIDE DOOR WOULD HAVE A 71" TRACK).

TRACK STANDOFFS ARE AVAILABLE FOR DOORS UP TO 2-1/4" THICK.

DOORS MORE THAN 1" OVER TYPICAL SIZES (i.e. 37" ON A NOMINAL 6" TRACK) REQUIRE THE TYPICAL HANGER OFFSET BE ALTERED. SEE INSTALLATION CUT SHEET FOR MORE INFORMATION.

IF YOUR DOOR IS A CUSTOM SIZE (i.e. 40"), YOU WILL HAVE TO REPOSITION ONE END STOP. DRILL ONE HOLE AT DESIRED LOCATION AND USE HEX BOLT TO FASTEN (NOT INCLUDED). YOU MAY ALSO USE ADJUSTABLE END STOPS (OPTIONAL ACCESSORY) OR REQUEST A CUSTOM FABRICATION.

FOR BI-PARTING DOORS, BUTT THE TRACK OF EACH KIT END TO END TIGHTLY. JOINING TRACKS IS NOT NECESSARY.

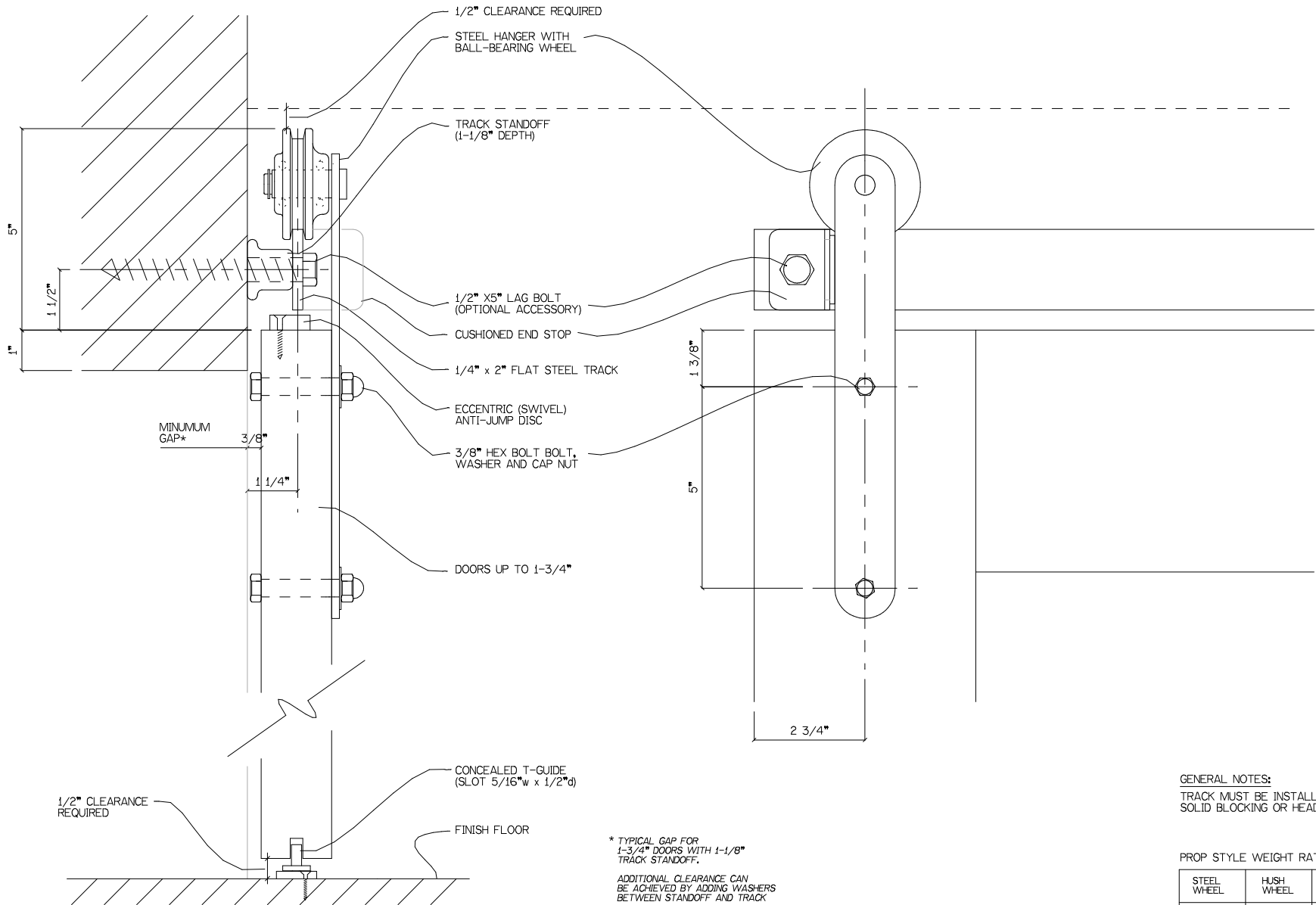

MINIMUM GAP\*

1/2" CLEARANCE REQUIRED

1/2" CLEARANCE REQUIRED

STEEL HANGER WITH BALL-BEARING WHEEL

TRACK STANDOFF (1-1/8" DEPTH)

1/2" X5" LAG BOLT (OPTIONAL ACCESSORY)

CUSHIONED END STOP

1/4" x 2" FLAT STEEL TRACK

ECCENTRIC (SWIVEL) ANTI-JUMP DISC

3/8" HEX BOLT, WASHER AND CAP NUT

DOORS UP TO 1-3/4"

CONCEALED T-GUIDE (SLOT 5/16"w x 1/2"d)

FINISH FLOOR

\* TYPICAL GAP FOR 1-3/4" DOORS WITH 1-1/8" TRACK STANDOFF.  
ADDITIONAL CLEARANCE CAN BE ACHIEVED BY ADDING WASHERS BETWEEN STANDOFF AND TRACK

GENERAL NOTES:  
TRACK MUST BE INSTALLED INTO SOLID BLOCKING OR HEAD CASING.

PROP STYLE WEIGHT RATINGS\*\*

STEEL WHEEL	HUSH WHEEL	WOOD WHEEL
200 LBS	200 LBS	80 LBS

\*\*RATING PER PAIR OF HANGERS

**REAL** SLIDING HARDWARE  
Real Carriage Door Company  
9803 44th AVE NW  
GIG HARBOR, WA 98332

**PROP FLAT TRACK**  
DESCRIPTION/NOTES: SECTION AND ELEVATION VIEWS

(DOORS UP TO 1-3/4")

THIS PRINT IS THE PROPERTY OF REAL CARRIAGE DOOR COMPANY, INC. AND IS LOANED TO THE RECIPIENT SUBJECT TO RETURN UPON DEMAND. ALL CONTENTS HEREIN ARE CONFIDENTIAL AND MUST NOT BE COPIED OR SUBMITTED TO OUTSIDE PARTIES FOR EXAMINATION WITHOUT THE EXPRESS WRITTEN CONSENT OF REAL CARRIAGE DOOR COMPANY, INC.

DRWG NO:  
DATE:

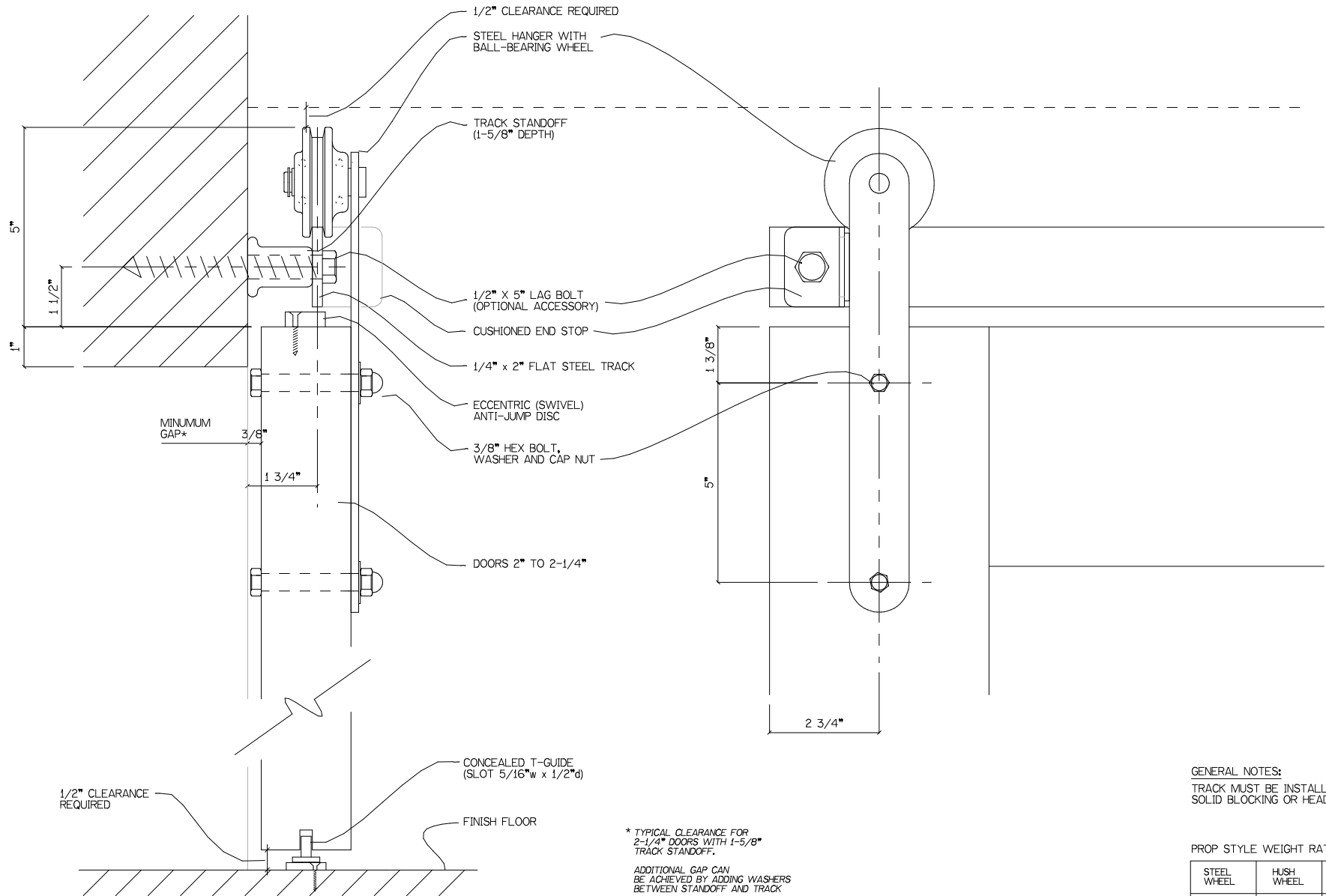

MINIMUM GAP\* 3/8"

\* TYPICAL CLEARANCE FOR 2-1/4" DOORS WITH 1-5/8" TRACK STANDOFF.  
ADDITIONAL GAP CAN BE ACHIEVED BY ADDING WASHERS BETWEEN STANDOFF AND TRACK

GENERAL NOTES:  
TRACK MUST BE INSTALLED INTO SOLID BLOCKING OR HEAD CASING.

PROP STYLE WEIGHT RATINGS\*\*

STEEL WHEEL	HUSH WHEEL	WOOD WHEEL
200 LBS	200 LBS	80 LBS

\*\* RATING PER PAIR OF HANGERS

**REAL**  
SLIDING  
HARDWARE

Real Carriage  
Door Company

9803 44th AVE NW  
GIG HARBOR, WA 98332

**PROP FLAT TRACK**  
(DOORS 2" TO 2-1/4")

DESCRIPTION/NOTES:  
SECTION AND ELEVATION VIEWS

(DOORS 2" TO 2-1/4")

THIS PRINT IS THE PROPERTY OF REAL CARRIAGE DOOR COMPANY, INC. AND IS LOANED TO THE RECIPIENT SUBJECT TO RETURN UPON DEMAND. ALL CONTENTS HEREIN ARE CONFIDENTIAL AND MUST NOT BE COPIED OR SUBMITTED TO OUTSIDE PARTIES FOR EXAMINATION WITHOUT THE EXPRESS WRITTEN CONSENT OF REAL CARRIAGE DOOR COMPANY, INC.

DRWG NO:  
DATE:

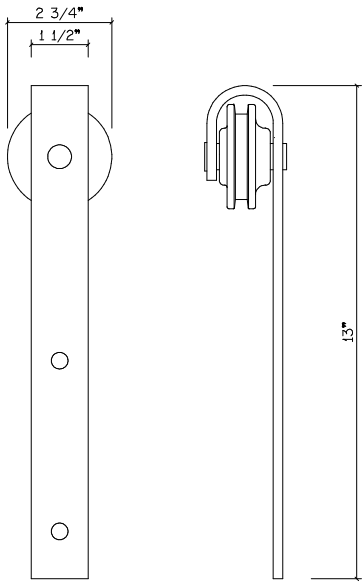

CLASSIC STYLE  
HANGER

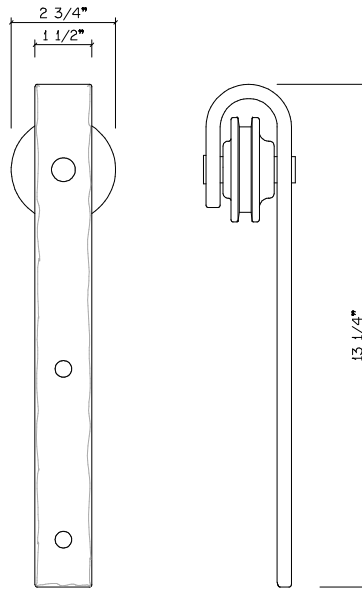

HAMMERED STYLE  
HANGER

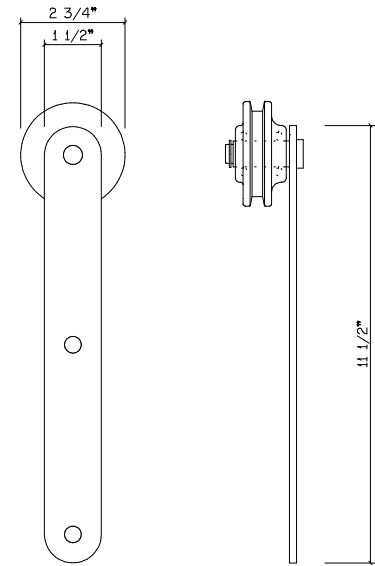

PROP STYLE  
HANGER

NOTE:  
HAMMERED HANGERS  
ARE HAND-FORGED  
AND DIMENSIONS MAY  
VARY SLIGHTLY

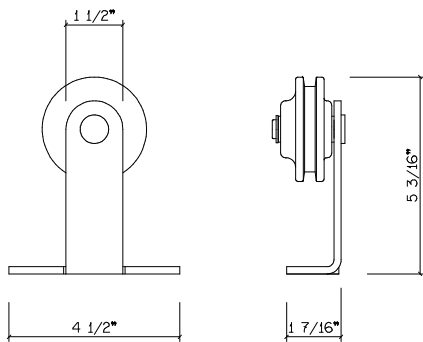

AERO STYLE  
HANGER

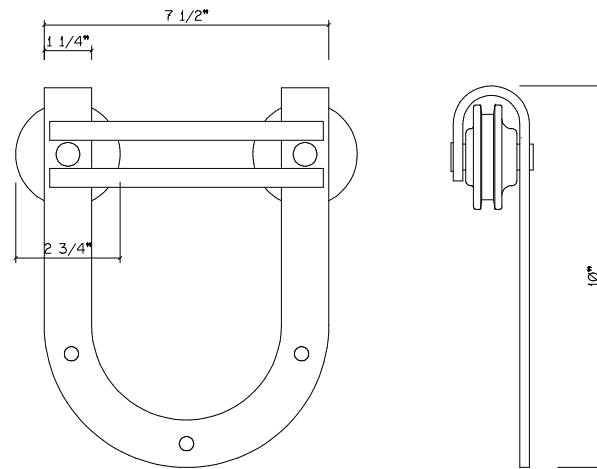

HORSESHOE STYLE  
HANGER

SF-04

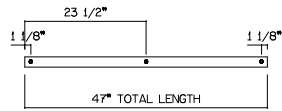

SF-09

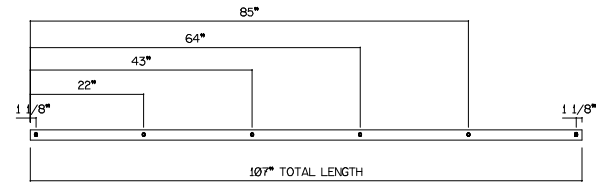

SF-05

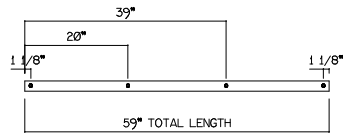

SF-10-2PC

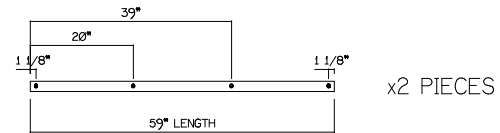

SF-06

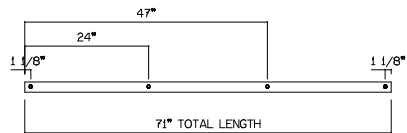

SF-12-2PC

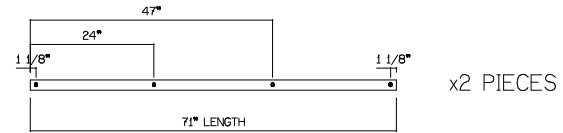

SF-07

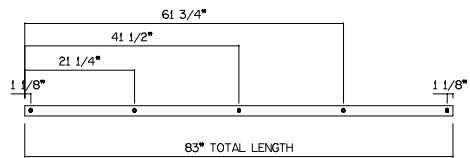

SF-10\*

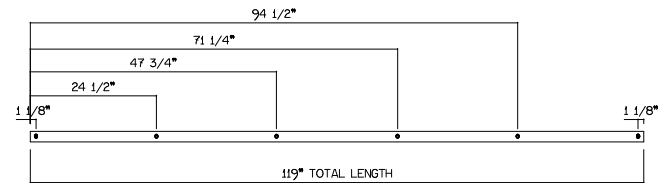

SF-08

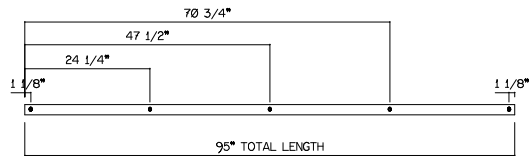

SF-12\*

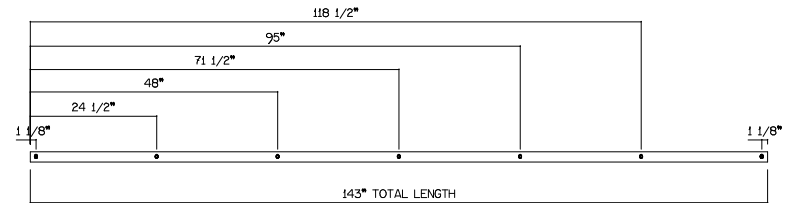

\*THESE ITEMS ARE TOO LONG FOR FEDEX AND MUST SHIP FREIGHT

# FLAT TRACK STANDARD LENGTHS (CLASSIC, HORSESHOE, HAMMERED, PROP AND AERO STYLES)

DESCRIPTION/NOTES: HOLE PATTERNS ARE EVENLY SPACED 24" ON CENTER OR LESS. STANDARD TRACK LENGTHS SHOWN. CUSTOM LENGTHS AVAILABLE.  
 NOTE: HOLE MEASUREMENTS ARE FOR GENERAL INFO ONLY AND NOT INTENDED FOR USE AS A DRILLING TEMPLATE.

**To install:**

Determine how wide the door 'overlap' will be. The overlap is the distance between the leading edge of the door when fully open, and the trailing edge of the door when fully closed (1).

Mark centerline of overlap and place center of guide on line (2).

Predrill and install on floor so door will hang plumb.

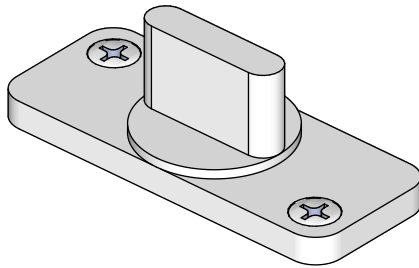
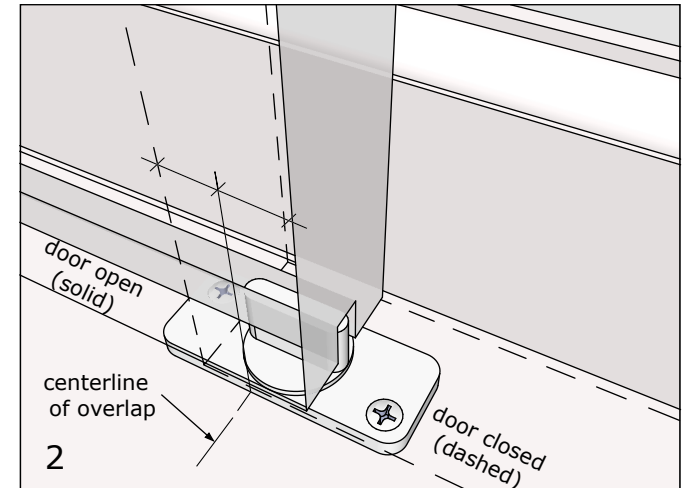
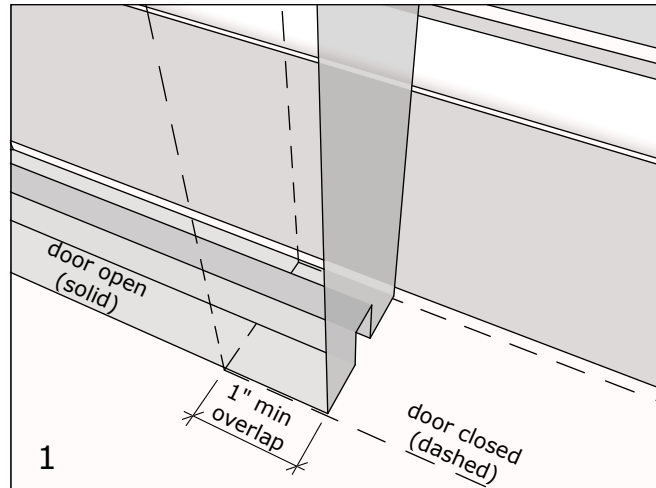

**General Notes:**

For use in wood doors when a semi-concealed look is desired.

Requires a 5/16"W x 1/2"H continuous slot in bottom of door

Smooth, high strength glide plastic guides door gently and quietly.

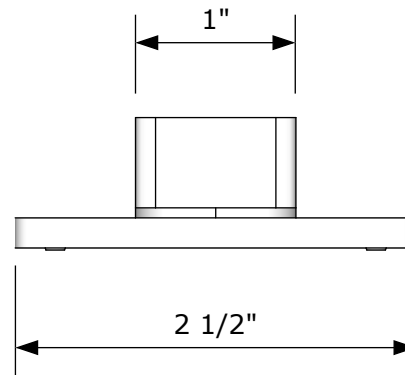

FRONT VIEW

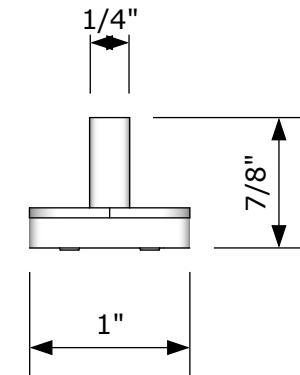

SIDE VIEW

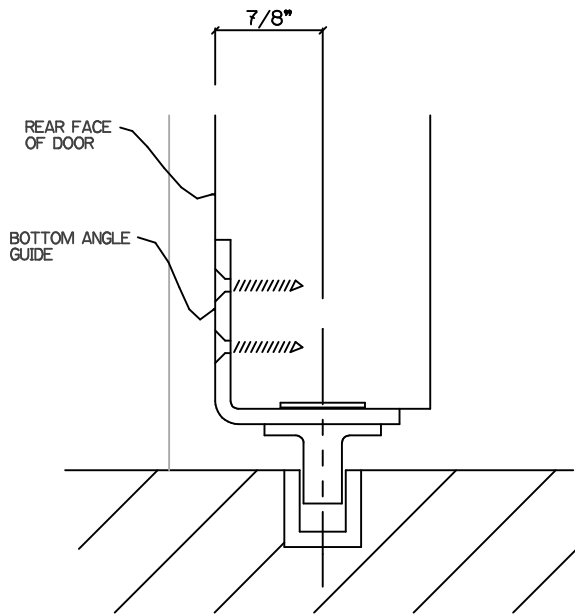

SECTION VIEW

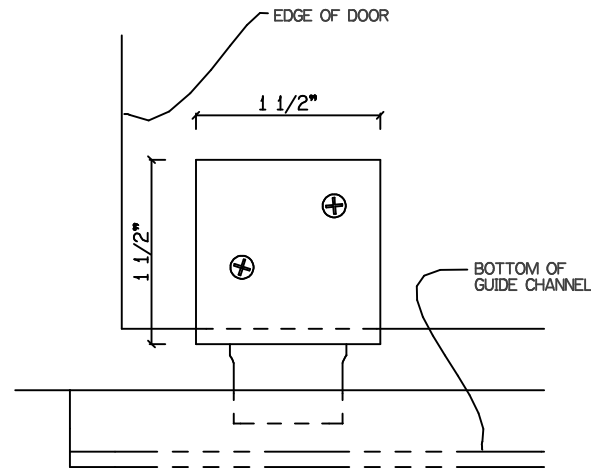

REAR VIEW

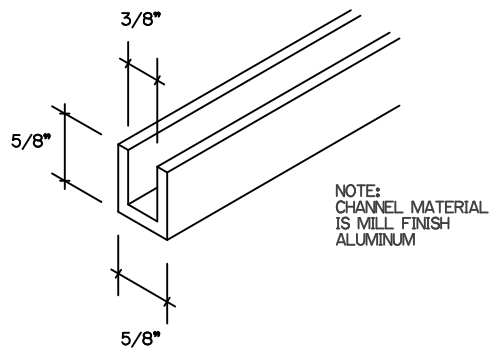

CHANNEL DIMENSIONS

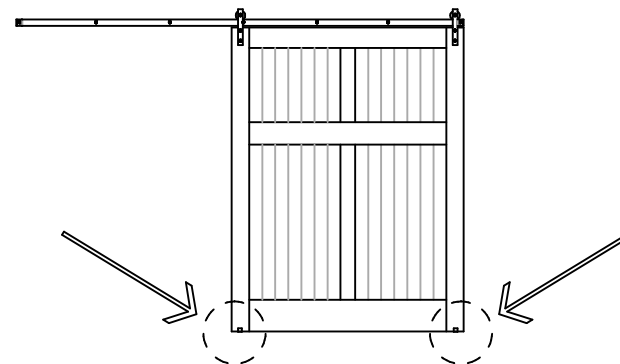

GUIDE LOCATIONS

GENERAL NOTES:

GUIDES DOOR AT FLOOR AND KEEPS DOOR FROM SWINGING IN AND OUT

INSTALL GUIDE TO REAR OF DOOR AFTER DOOR IS HUNG. DOOR SHOULD HANG PLUMB TO WALL.

CHANNEL MAY BE SCREWED TO SLOT IN A WOOD FLOOR OR SET IN CONCRETE. CHANNEL MUST BE COATED WITH A BITUMINOUS OR ASPHALT-BASED PAINT PRIOR TO CONCRETE EMBEDMENT

USE FOR ADDED EXTERIOR DOOR SECURITY / RIGIDITY