

GENERAL NOTES:

ACTUAL TRACK LENGTHS ARE 1" LESS THAN 2X THE NOMINAL DOOR WIDTH (i.e., A 36" WIDE DOOR WOULD HAVE A 71" TRACK).

TRACK STANDOFFS ARE AVAILABLE FOR DOORS UP TO 2-1/4" THICK.

DOORS MORE THAN 1" OVER TYPICAL SIZES (i.e. 37" ON A NOMINAL 6" TRACK) REQUIRE THE TYPICAL HANGER OFFSET BE ALTERED. SEE INSTALLATION CUT SHEET FOR MORE INFORMATION.

IF YOUR DOOR IS A CUSTOM SIZE (i.e. 40"), YOU WILL HAVE TO REPOSITION ONE END STOP, DRILL ONE HOLE AT DESIRED LOCATION AND USE HEX BOLT TO FASTEN (NOT INCLUDED). YOU MAY ALSO USE ADJUSTABLE END STOPS (OPTIONAL ACCESSORY) OR REQUEST A CUSTOM FABRICATION.

FOR BI-PARTING DOORS, BUTT THE TRACK OF EACH KIT END TO END TIGHTLY. JOINING TRACKS IS NOT NECESSARY.

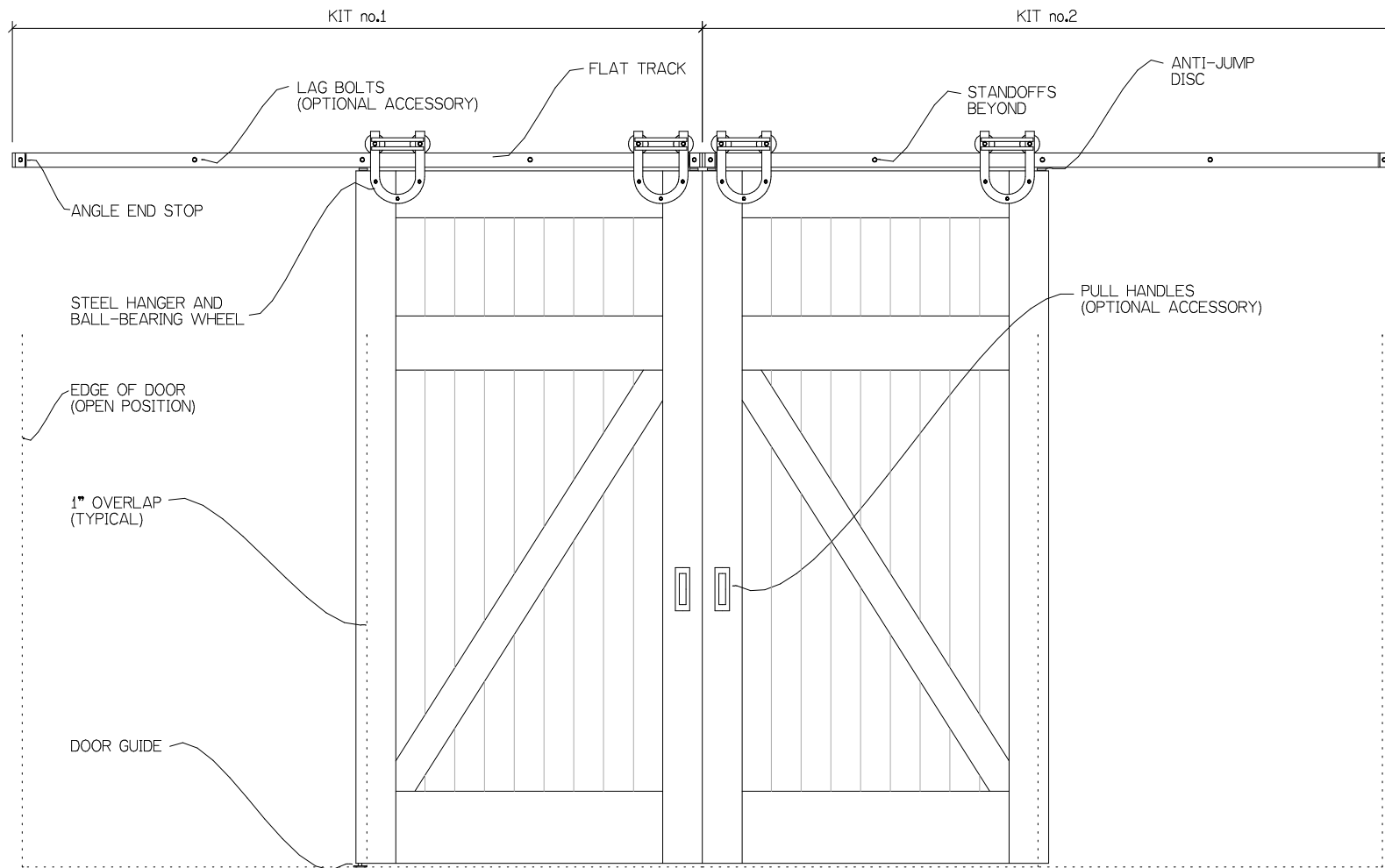

GENERAL NOTES:

ACTUAL TRACK LENGTHS ARE 1" LESS THAN 2X THE NOMINAL DOOR WIDTH (i.e., A 36" WIDE DOOR WOULD HAVE A 71" TRACK).

TRACK STANDOFFS ARE AVAILABLE FOR DOORS UP TO 2-1/4" THICK.

DOORS MORE THAN 1" OVER TYPICAL SIZES (i.e. 37" ON A NOMINAL 6" TRACK) REQUIRE THE TYPICAL HANGER OFFSET BE ALTERED. SEE INSTALLATION CUT SHEET FOR MORE INFORMATION.

IF YOUR DOOR IS A CUSTOM SIZE (i.e. 40"), YOU WILL HAVE TO REPOSITION ONE END STOP. DRILL ONE HOLE AT DESIRED LOCATION AND USE HEX BOLT TO FASTEN (NOT INCLUDED). YOU MAY ALSO USE ADJUSTABLE END STOPS (OPTIONAL ACCESSORY) OR REQUEST A CUSTOM FABRICATION.

FOR BI-PARTING DOORS, BUTT THE TRACK OF EACH KIT END TO END TIGHTLY. JOINING TRACKS IS NOT NECESSARY.

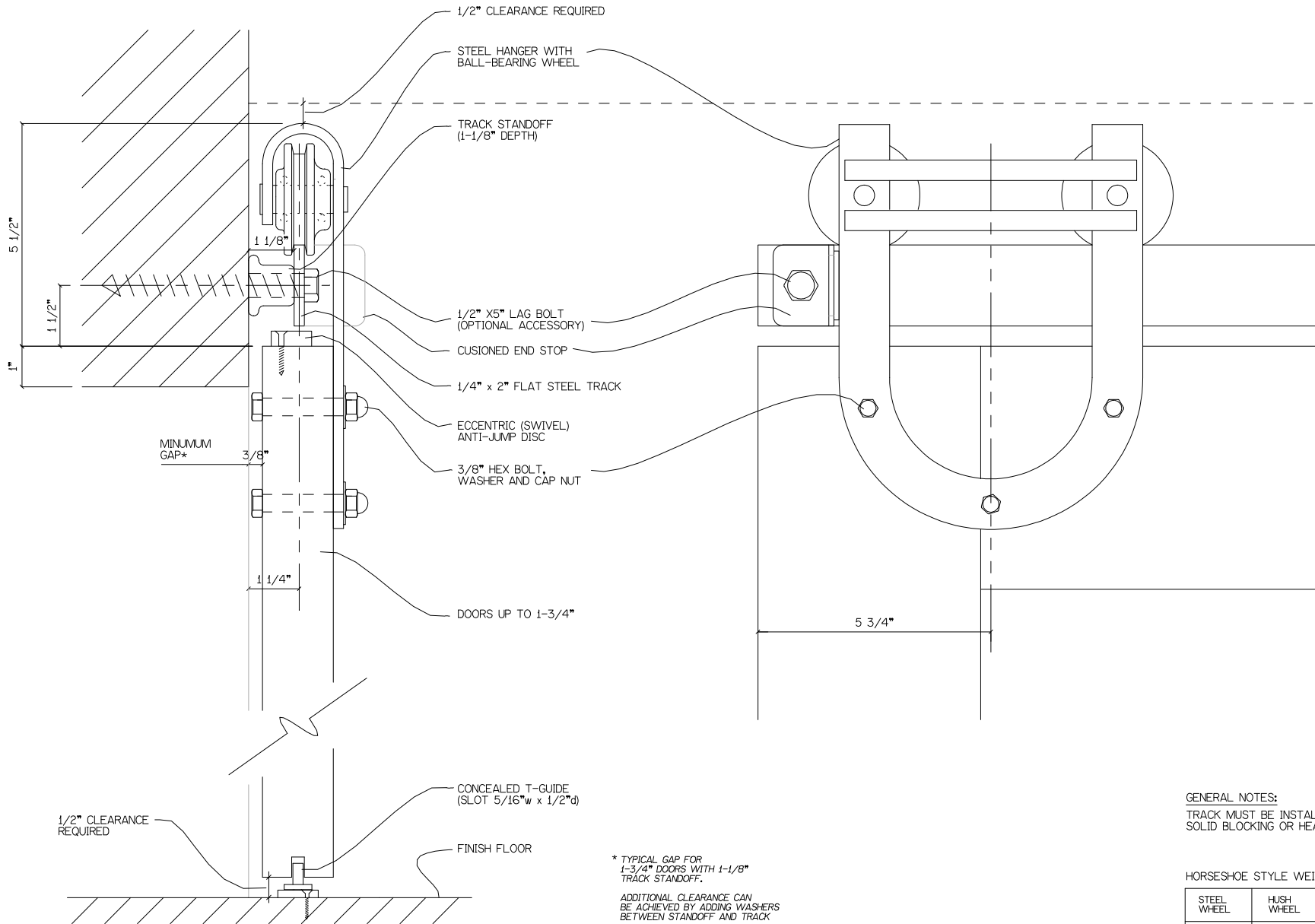

GENERAL NOTES:
 TRACK MUST BE INSTALLED INTO
 SOLID BLOCKING OR HEAD CASING.

HORSESHOE STYLE WEIGHT RATINGS**

STEEL WHEEL	HUSH WHEEL	WOOD WHEEL
550 LBS	550 LBS	110 LBS

**RATING PER PAIR OF HANGERS

* TYPICAL GAP FOR
 1-3/4" DOORS WITH 1-1/8"
 TRACK STANDOFF.
 ADDITIONAL CLEARANCE CAN
 BE ACHIEVED BY ADDING WASHERS
 BETWEEN STANDOFF AND TRACK

REAL SLIDING HARDWARE
 Real Carriage Door Company
 9803 44th AVE NW
 GIG HARBOR, WA 98332

HORSESHOE FLAT TRACK (DOORS UP TO 1-3/4")

DESCRIPTION/NOTES: SECTION AND ELEVATION VIEWS

THIS PRINT IS THE PROPERTY OF REAL CARRIAGE DOOR COMPANY, INC. AND IS LOANED TO THE RECIPIENT SUBJECT TO RETURN UPON DEMAND. ALL CONTENTS HEREIN ARE CONFIDENTIAL AND MUST NOT BE COPIED OR SUBMITTED TO OUTSIDE PARTIES FOR EXAMINATION WITHOUT THE EXPRESS WRITTEN CONSENT OF REAL CARRIAGE DOOR COMPANY, INC.

DRWG NO:
 DATE:

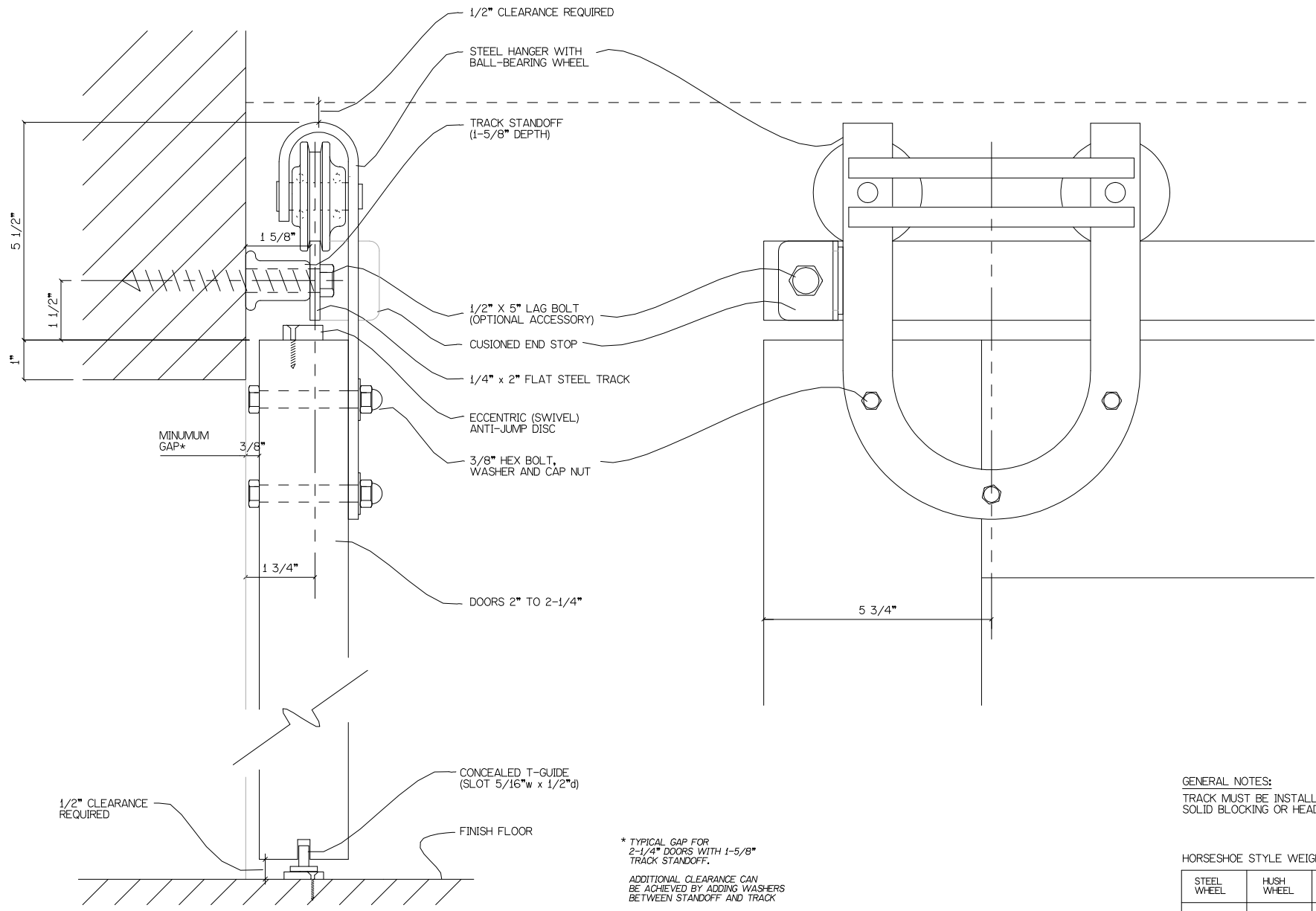

GENERAL NOTES:
 TRACK MUST BE INSTALLED INTO
 SOLID BLOCKING OR HEAD CASING.

HORSESHOE STYLE WEIGHT RATINGS**

STEEL WHEEL	HUSH WHEEL	WOOD WHEEL
550 LBS	550 LBS	110 LBS

**RATING PER PAIR OF HANGERS

* TYPICAL GAP FOR
 2-1/4" DOORS WITH 1-5/8"
 TRACK STANDOFF.
 ADDITIONAL CLEARANCE CAN
 BE ACHIEVED BY ADDING WASHERS
 BETWEEN STANDOFF AND TRACK

REAL
 SLIDING
 HARDWARE
 copyright 2013
 Real Carriage
 Door Company
 9803 44th AVE NW
 GIG HARBOR, WA 98332

HORSESHOE FLAT TRACK (DOORS 2" TO 2-1/4")

DESCRIPTION/NOTES: SECTION AND ELEVATION VIEWS

THIS PRINT IS THE PROPERTY OF REAL CARRIAGE
 DOOR COMPANY, INC. AND IS LOANED TO THE
 RECIPIENT SUBJECT TO RETURN UPON DEMAND.
 ALL CONTENTS HEREIN ARE CONFIDENTIAL AND
 MUST NOT BE COPIED OR SUBMITTED TO OUTSIDE
 PARTIES FOR EXAMINATION WITHOUT THE
 EXPRESS WRITTEN CONSENT OF REAL CARRIAGE
 DOOR COMPANY, INC.

DRWG NO:

 DATE:

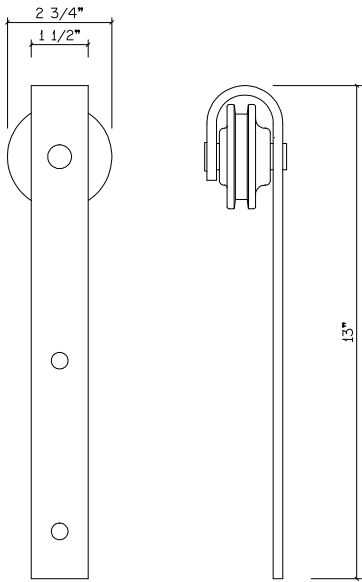

CLASSIC STYLE
HANGER

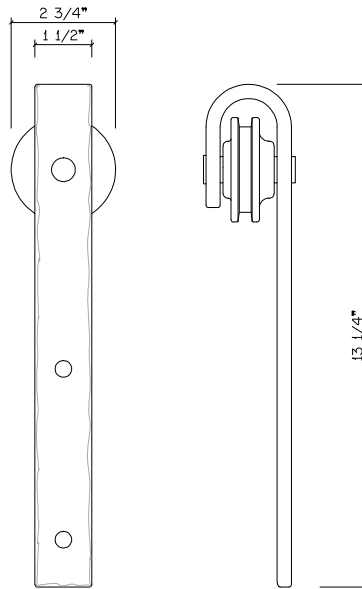

HAMMERED STYLE
HANGER

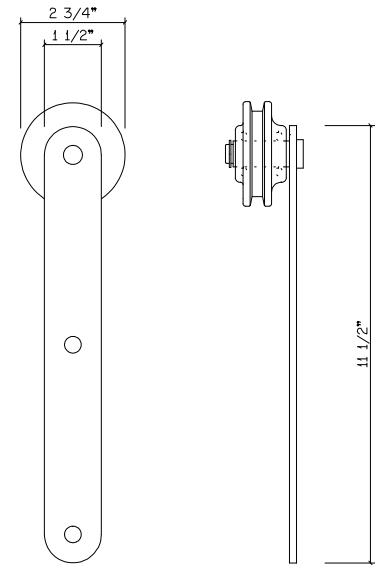

PROP STYLE
HANGER

NOTE:
HAMMERED HANGERS
ARE HAND-FORGED
AND DIMENSIONS MAY
VARY SLIGHTLY

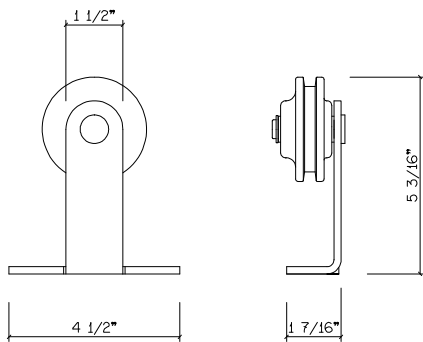

AERO STYLE
HANGER

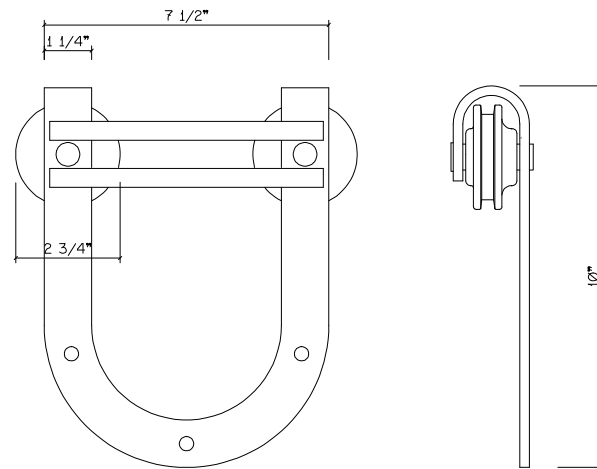

HORSESHOE STYLE
HANGER

SF-04

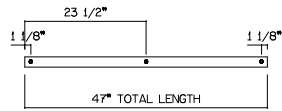

SF-09

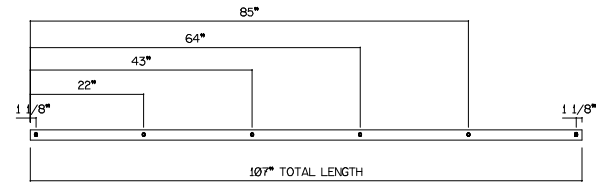

SF-05

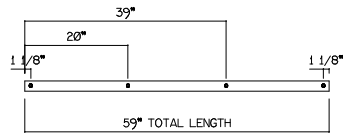

SF-10-2PC

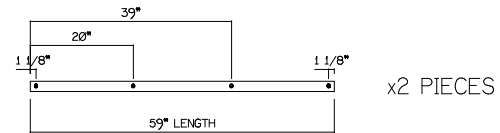

SF-06

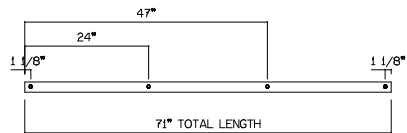

SF-12-2PC

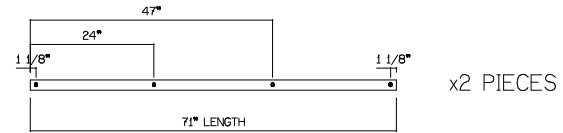

SF-07

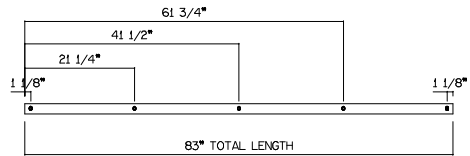

SF-10*

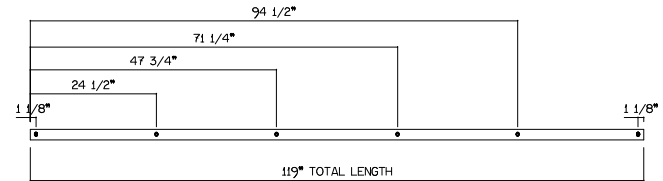

SF-08

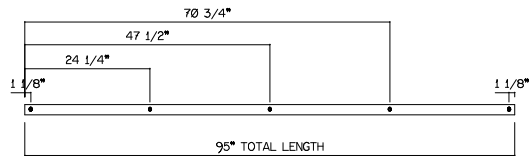

SF-12*

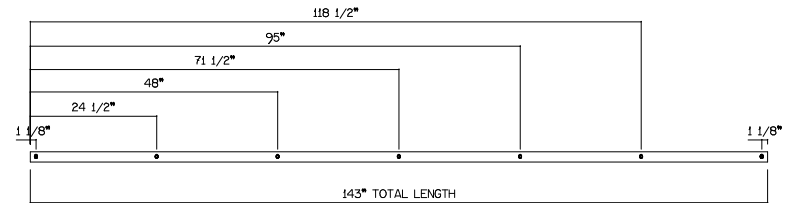

*THESE ITEMS ARE TOO LONG FOR FEDEX AND MUST SHIP FREIGHT

FLAT TRACK STANDARD LENGTHS (CLASSIC, HORSESHOE, HAMMERED, PROP AND AERO STYLES)

DESCRIPTION/NOTES: HOLE PATTERNS ARE EVENLY SPACED 24" ON CENTER OR LESS. STANDARD TRACK LENGTHS SHOWN. CUSTOM LENGTHS AVAILABLE.
NOTE: HOLE MEASUREMENTS ARE FOR GENERAL INFO ONLY AND NOT INTENDED FOR USE AS A DRILLING TEMPLATE.

THIS PRINT IS THE PROPERTY OF REAL CARRIAGE DOOR COMPANY, INC. AND IS LOANED TO THE RECIPIENT SUBJECT TO RETURN UPON DEMAND. ALL CONTENTS HEREIN ARE CONFIDENTIAL AND MUST NOT BE COPIED OR SUBMITTED TO OUTSIDE PARTIES FOR EXAMINATION WITHOUT THE EXPRESS WRITTEN CONSENT OF REAL CARRIAGE DOOR COMPANY, INC.

DRWG NO:
DATE:

To install:

Determine how wide the door 'overlap' will be. The overlap is the distance between the leading edge of the door when fully open, and the trailing edge of the door when fully closed (1).

Mark centerline of overlap and place center of guide on line (2).

Predrill and install on floor so door will hang plumb.

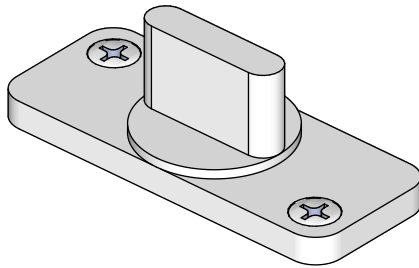
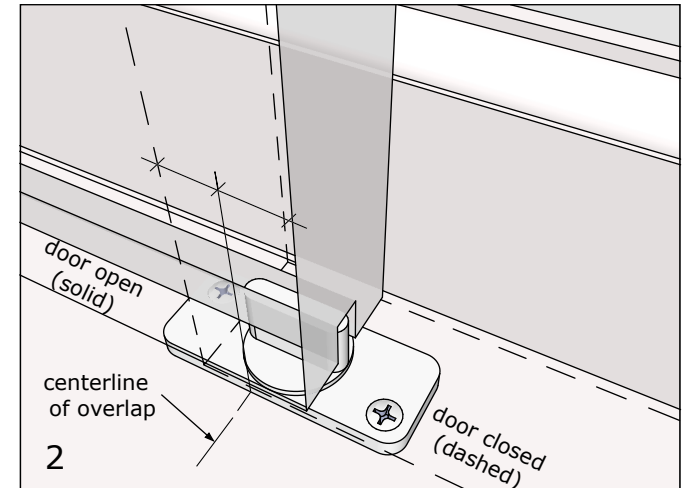
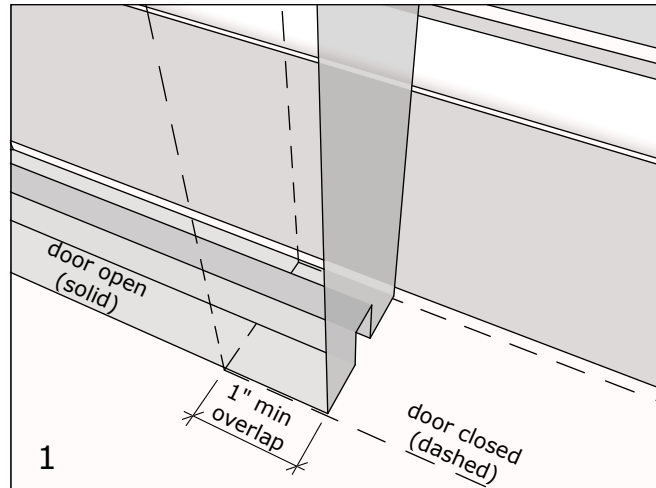

General Notes:

For use in wood doors when a semi-concealed look is desired.

Requires a 5/16"W x 1/2"H continuous slot in bottom of door

Smooth, high strength glide plastic guides door gently and quietly.

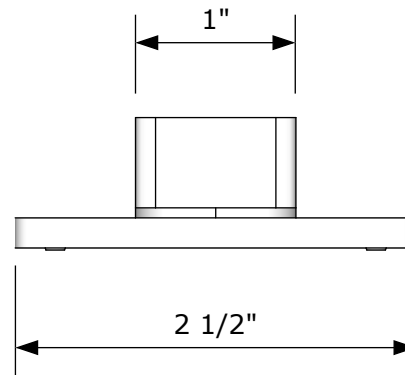

FRONT VIEW

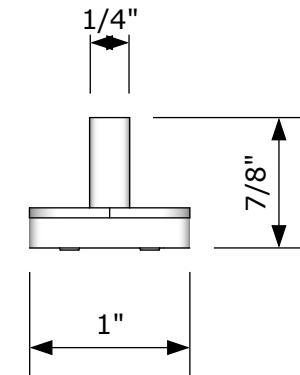

SIDE VIEW

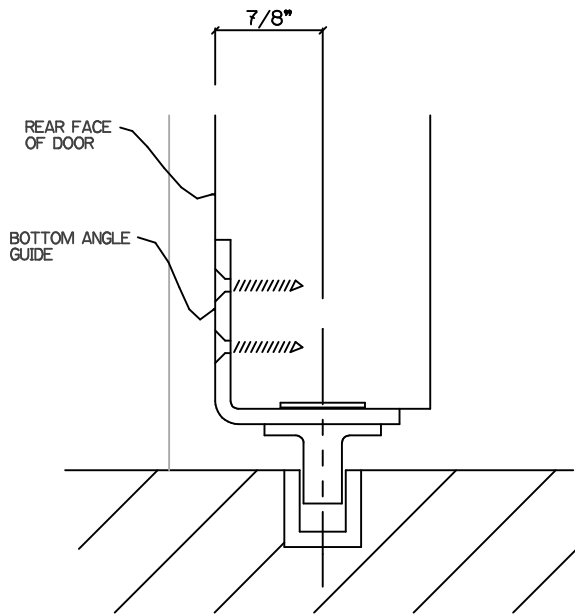

SECTION VIEW

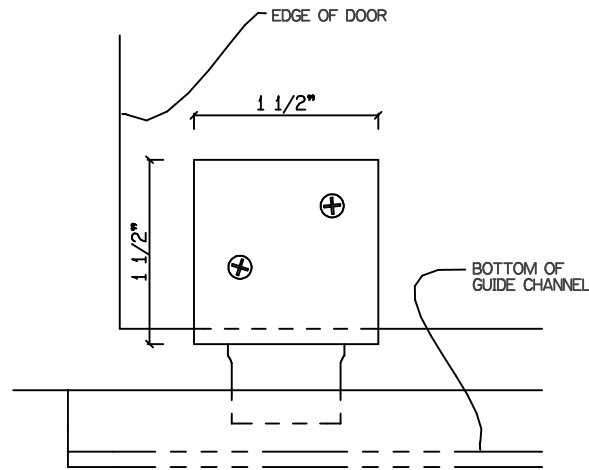

REAR VIEW

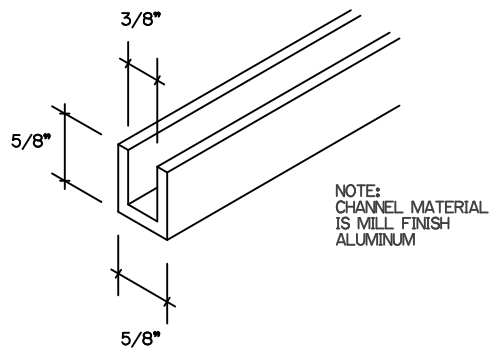

CHANNEL DIMENSIONS

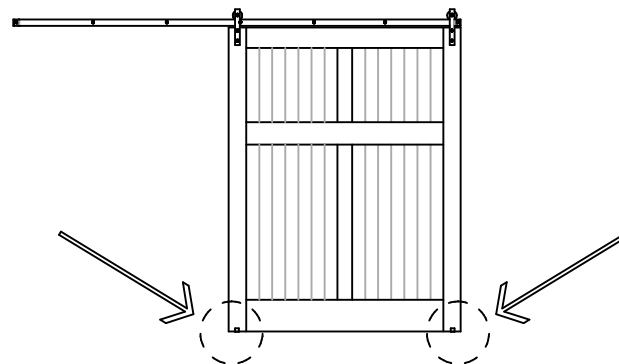

GUIDE LOCATIONS

GENERAL NOTES:

GUIDES DOOR AT FLOOR AND KEEPS DOOR FROM SWINGING IN AND OUT

INSTALL GUIDE TO REAR OF DOOR AFTER DOOR IS HUNG. DOOR SHOULD HANG PLUMB TO WALL.

CHANNEL MAY BE SCREWED TO SLOT IN A WOOD FLOOR OR SET IN CONCRETE. CHANNEL MUST BE COATED WITH A BITUMINOUS OR ASPHALT-BASED PAINT PRIOR TO CONCRETE EMBEDMENT

USE FOR ADDED EXTERIOR DOOR SECURITY / RIGIDITY